



**siteScapes**

**CityView** Planters





888.331.9464 402.421.9479 fax  
 P.O. Box 22326 Lincoln, NE 68542  
[www.sitescapesonline.com](http://www.sitescapesonline.com)  
[info@sitescapesonline.com](mailto:info@sitescapesonline.com)

## CityView Vertical Strap Planters

### CityView Planters

Planters provide color and life to otherwise inorganic settings. Twenty-two gallon liners provide potting volume suitable for a large variety of plantings.

### Materials

5/16" straps for maximum durability

### Sustainability and LEED

CityView planters have a recycled material content of 99% of which 87% is post consumer content. This content may vary based on the product design, product material type, and interchangeable piece parts. All styles are 100% recyclable. For more information about SiteScapes sustainable products and policies, please refer to our Environmental Statement.

Pictured this page

left: CityView vertical strap planter CV4-1000 (Forest). right: CityView vertical strap planter CV4-1000 (Forest).

### Finishes

SiteScapes offers product in both a standard powdercoat and its own proprietary Duarcoat finish. Both finishes are designed to weather the elements and are guaranteed not to rust, chip, peel, or fade. Call for a standard color chart.

### [www.sitescapesonline.com](http://www.sitescapesonline.com)

For more information visit our website where you can download product drawings, photos, product brochures, CSI specs, and other technical data.

### CityView planter dimensions

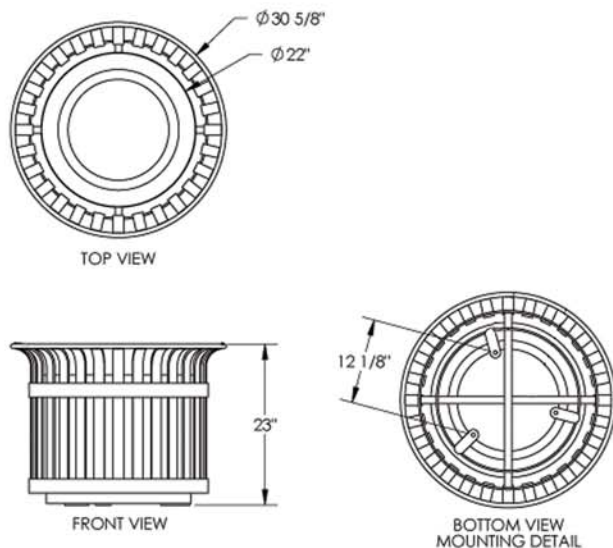

CityView Planters are currently offered in only one style. CV4-1000 to specify.



30% POST CONSUMER CONTENT