



SITESCAPES

P.O. Box 22326
Lincoln, NE 68542

PF: 402/421-9464
FX: 402/421-9479

WEBSITE: www.sitescapesonline.com
E-MAIL: info@sitescapesonline.com

TITLE *TALLGRASS
CAROUSEL TABLE*

PRODUCT NO.
TG6-1120

INCH TOLERANCES U.O.S.
FRACTION-- $\pm 1/16"$
ANG----- $\pm 1^\circ$

THE INFORMATION CONTAINED IN THIS DRAWING IS THE SOLE PROPERTY OF SITESCAPES, INC. ANY REPRODUCTION IN PART OR AS A WHOLE WITHOUT THE WRITTEN PERMISSION OF SITESCAPES, INC. IS PROHIBITED.

*Available in powder coat and DuraCoat finishes

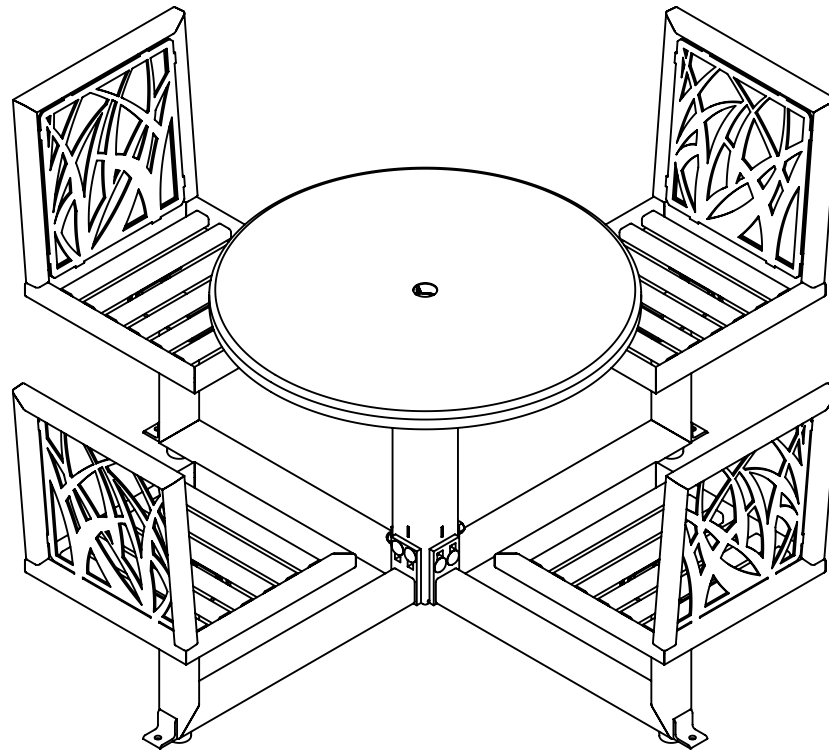



SITESCAPES

P.O. Box 22326
Lincoln, NE 68542

PF: 402/421-9464

FX: 402/421-9479

WEBSITE: www.sitescapesonline.com

E-MAIL: info@sitescapesonline.com

TITLE *TALLGRASS
CAROUSEL TABLE*

PRODUCT NO.
TG6-1120

INCH TOLERANCES U.O.S.

FRACTION-- $\pm 1/16"$

ANG----- $\pm 1^\circ$

THE INFORMATION CONTAINED IN THIS DRAWING IS THE SOLE PROPERTY OF SITESCAPES, INC. ANY REPRODUCTION IN PART OR AS A WHOLE WITHOUT THE WRITTEN PERMISSION OF SITESCAPES, INC. IS PROHIBITED.

*Available in powder coat and DuraCoat finishes

MATERIALS LIST:

- (1) Table Top - 12 Ga. x $\phi 36"$ Stainless Steel
- (2) Table Top Post - 4" Sq. x 1/8" Wall Steel Tubing
- (3) Chair Support Tubes - 2 1/2" Sq. x 1/8" Wall Steel Tubing
- (4) Chair Frame- 1 1/2" Sq. x 1/8" Wall Steel Tubing
- (5) Chair Back- 7 GA. Mild Steel Plate
- (6) 1/2" x 6" Anchor Bolts (Not Shown)

