



P.O. Box 22326
Lincoln, NE 68542

PF: 402/421-9464 | WEBSITE: www.sitescapesonline.com
FX: 402/421-9479 | E-MAIL: info@sitescapesonline.com

TITLE *CITYVIEW
FLAT BENCH*

PRODUCT NO.
CV1-2110

INCH TOLERANCES U.O.S.
FRACTION-- $\pm 1/16"$
ANG----- $\pm 1^\circ$

THE INFORMATION CONTAINED IN THIS DRAWING IS THE SOLE PROPERTY OF SITESCAPES, INC. ANY REPRODUCTION IN PART OR AS A WHOLE WITHOUT THE WRITTEN PERMISSION OF SITESCAPES, INC. IS PROHIBITED.

*Available in powder coat and DuraCoat finishes

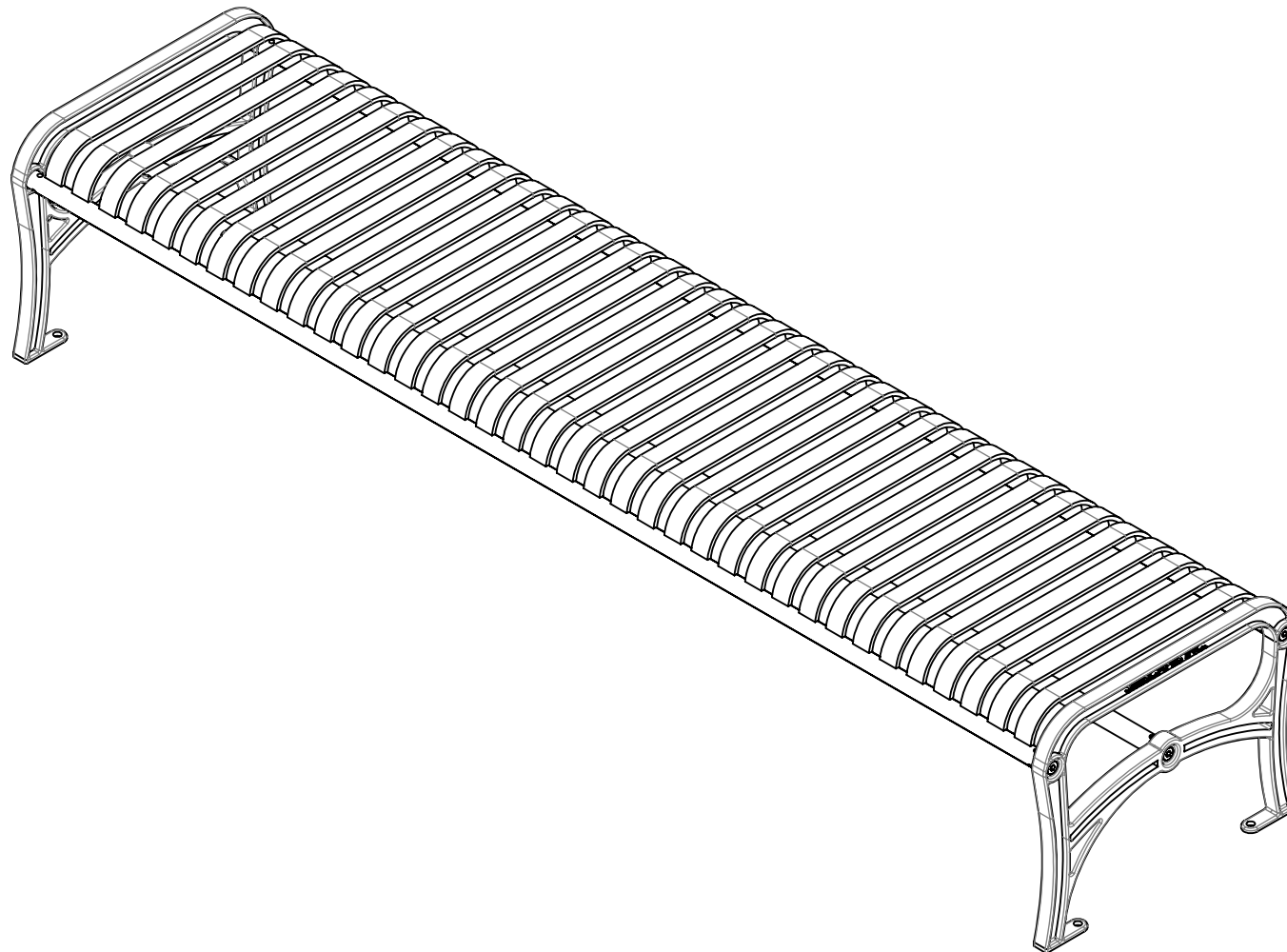



P.O. Box 22326
Lincoln, NE 68542

PF: 402/421-9464
FX: 402/421-9479

WEBSITE: www.sitescapesonline.com
E-MAIL: info@sitescapesonline.com

TITLE
*CITYVIEW
FLAT BENCH*

PRODUCT NO.
CV1-2110

INCH TOLERANCES U.O.S.
FRACTION-- $\pm 1/16"$
ANG----- $\pm 1^\circ$

THE INFORMATION CONTAINED IN THIS DRAWING IS THE SOLE PROPERTY OF SITESCAPES, INC. ANY REPRODUCTION IN PART OR AS A WHOLE WITHOUT THE WRITTEN PERMISSION OF SITESCAPES, INC. IS PROHIBITED.

*Available in powder coat and DuraCoat finishes

Materials List

- (1) Seat Straps - 5/16" x 1 1/2" Steel Flat Bar
- (2) Support Pipes - ϕ 1.315" x .133" Steel Pipe
- (3) End Units - 1 1/4" Cast Iron with 9/16" Mounting Holes
- (4) Mounted with Four ϕ 1/2" x 4-5" Stainless Steel Anchor Bolts (Customer Supplied)

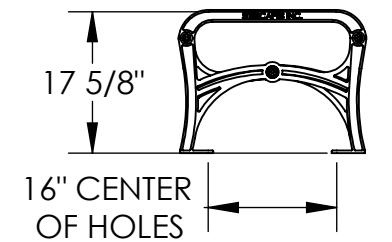
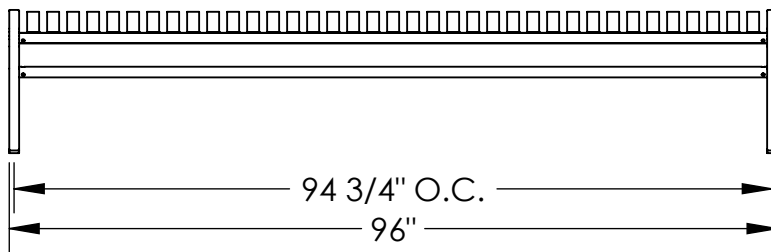
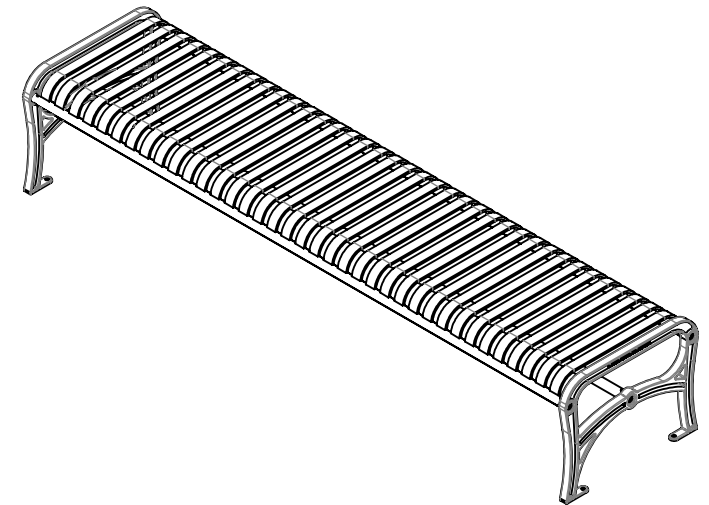
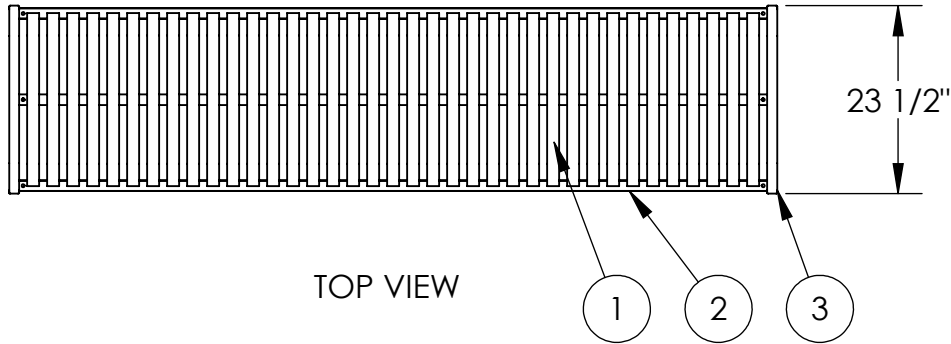

FRONT VIEW

RIGHT SIDE VIEW