



P.O. Box 22326
Lincoln, NE 68542

PF: 402/421-9464 | WEBSITE: www.sitescapesonline.com
FX: 402/421-9479 | E-MAIL: info@sitescapesonline.com

TITLE *CITYVIEW
TABLE AND BENCHES*

PRODUCT NO.
CV6-4362

INCH TOLERANCES U.O.S.
FRACTION-- $\pm 1/16"$
ANG----- $\pm 1^\circ$

THE INFORMATION CONTAINED IN THIS DRAWING IS THE SOLE PROPERTY OF SITESCAPES, INC. ANY REPRODUCTION IN PART OR AS A WHOLE WITHOUT THE WRITTEN PERMISSION OF SITESCAPES, INC. IS PROHIBITED.

*Available in powder coat and DuraCoat finishes

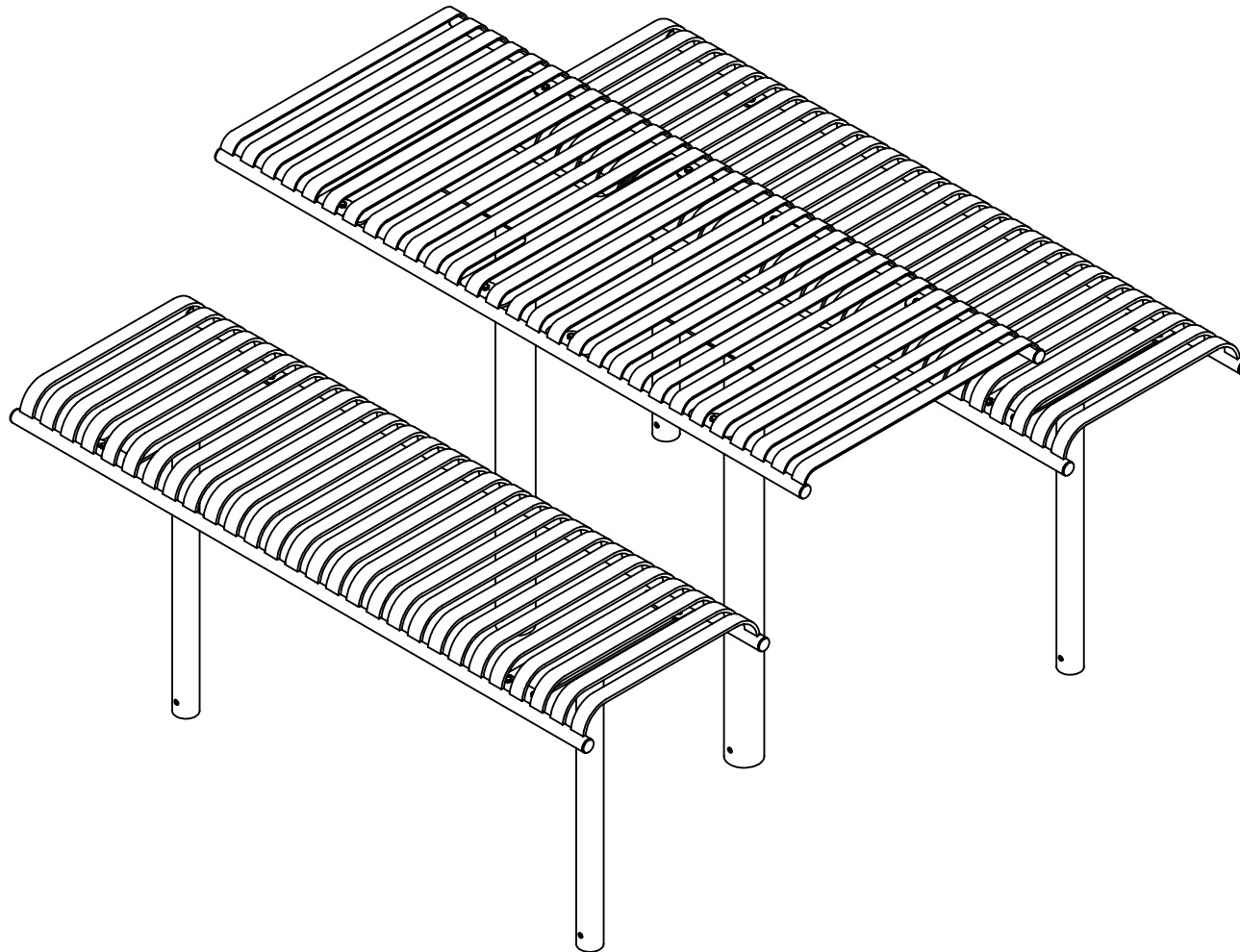



P.O. Box 22326
Lincoln, NE 68542

PF: 402/421-9464 | WEBSITE: www.sitescapesonline.com
FX: 402/421-9479 | E-MAIL: info@sitescapesonline.com

TITLE *CITYVIEW*
TABLE AND BENCHES

PRODUCT NO.
CV6-4362

INCH TOLERANCES U.O.S.
FRACTION-- $\pm 1/16"$
ANG----- $\pm 1^\circ$

THE INFORMATION CONTAINED IN THIS DRAWING IS THE SOLE PROPERTY OF SITESCAPES, INC. ANY REPRODUCTION IN PART OR AS A WHOLE WITHOUT THE WRITTEN PERMISSION OF SITESCAPES, INC. IS PROHIBITED.

*Available in powder coat and DuraCoat finishes

MATERIALS LIST

- (1) Table Straps - 3/16" x 1 1/2" Steel Flat Bar
- (2) Seat Straps - 5/16" x 1 1/2" Steel Flat Bar
- (3) Support Pipes - $\phi 1.315"$ x .133" Wall Steel Tubing
- (4) Table Posts - $\phi 3 1/2"$ x 1/8" Wall Steel Tubing
- (5) Bench Posts - $\phi 2 3/8"$ x .154" Wall Steel Tubing
- (6) Support Plates - 1/4" Steel Plate

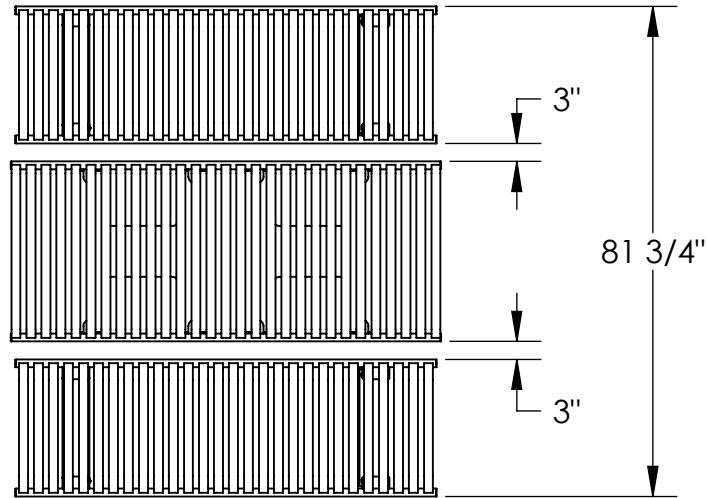

TOP VIEW

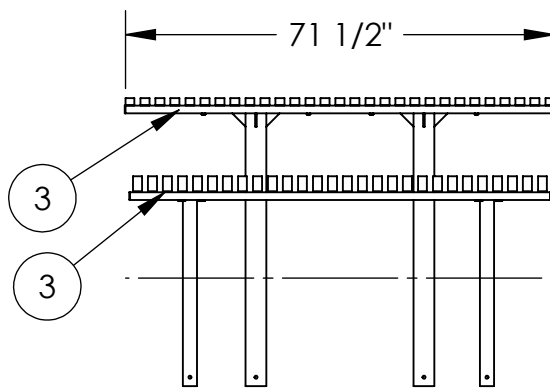
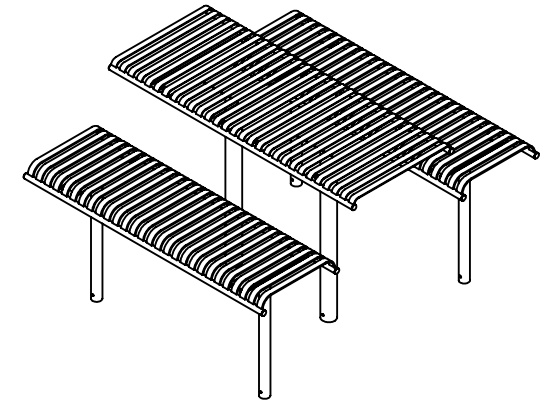

FRONT VIEW

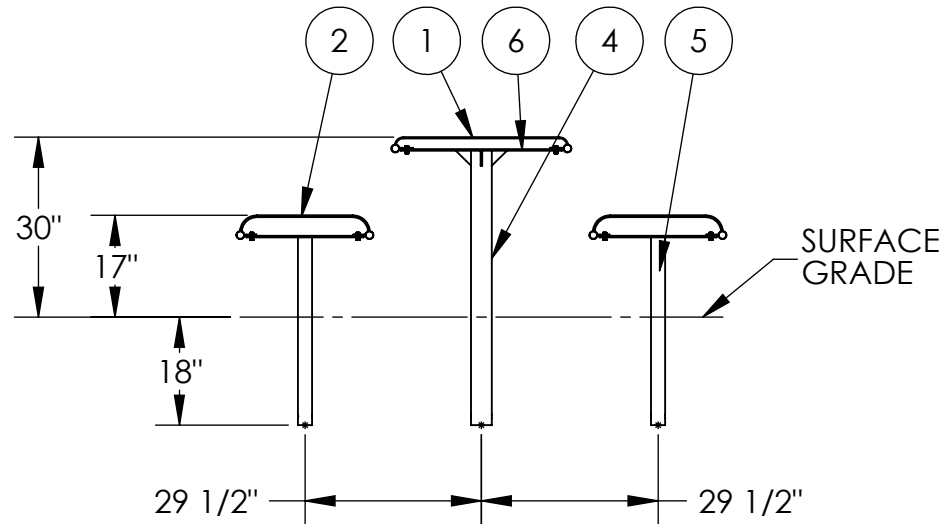

END VIEW