



P.O. Box 22326  
Lincoln, NE 68542

PF: 402/421-9464 | WEBSITE: [www.sitescapesonline.com](http://www.sitescapesonline.com)  
FX: 402/421-9479 | E-MAIL: [info@sitescapesonline.com](mailto:info@sitescapesonline.com)

TITLE *CITYVIEW  
PLANTER*

PRODUCT NO.  
*CV4-1000*

INCH TOLERANCES U.O.S.  
FRACTION--  $\pm 1/16"$   
ANG-----  $\pm 1^\circ$

THE INFORMATION CONTAINED IN THIS DRAWING IS THE SOLE PROPERTY OF SITESCAPES, INC. ANY REPRODUCTION IN PART OR AS A WHOLE WITHOUT THE WRITTEN PERMISSION OF SITESCAPES, INC. IS PROHIBITED.

\*Available in powder coat and DuraCoat finishes

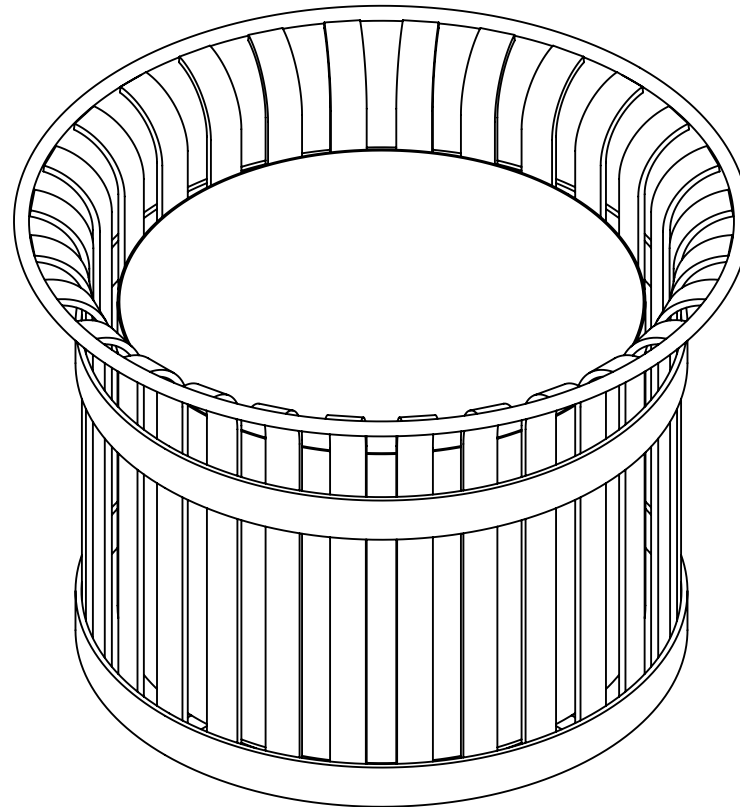



P.O. Box 22326  
Lincoln, NE 68542

PF: 402/421-9464 | WEBSITE: [www.sitescapesonline.com](http://www.sitescapesonline.com)  
FX: 402/421-9479 | E-MAIL: [info@sitescapesonline.com](mailto:info@sitescapesonline.com)

TITLE *CITYVIEW  
PLANTER*

PRODUCT NO.  
*CV4-1000*

INCH TOLERANCES U.O.S.  
FRACTION--  $\pm 1/16$ "  
ANG-----  $\pm 1^\circ$

THE INFORMATION CONTAINED IN THIS DRAWING IS THE SOLE PROPERTY OF SITESCAPES, INC. ANY REPRODUCTION IN PART OR AS A WHOLE WITHOUT THE WRITTEN PERMISSION OF SITESCAPES, INC. IS PROHIBITED.

\*Available in powder coat and DuraCoat finishes

Materials List

- (1) Vertical Straps - 5/16" x 1 1/2" Steel Flat Bar
- (2) Top Ring -  $\phi 5/8$ " Steel Round Bar
- (3) Support Rings - 1/4" x 2" Steel Flat Bar
- (4) Support Bars - 1/2" x 1" Steel Flat Bar
- (5) Mounting Plates - 1/4" x 1 1/2" Stainless Steel Plate
- (6) Mounted with Three  $\phi 1/2$ " x 4-5" Stainless Steel Anchor Bolts (Customer Supplied)
- (7) Rigid Plastic Liner Included

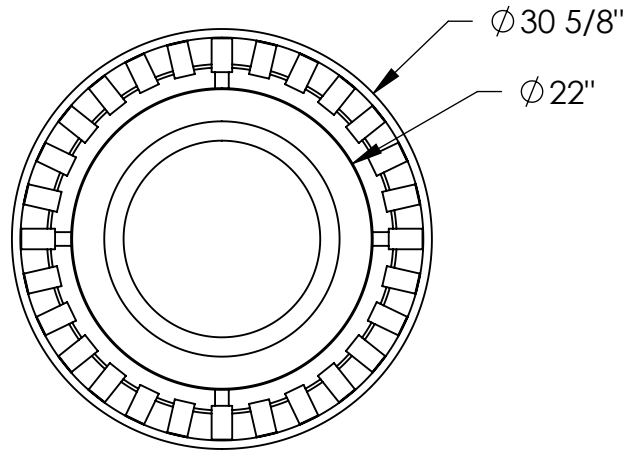

TOP VIEW

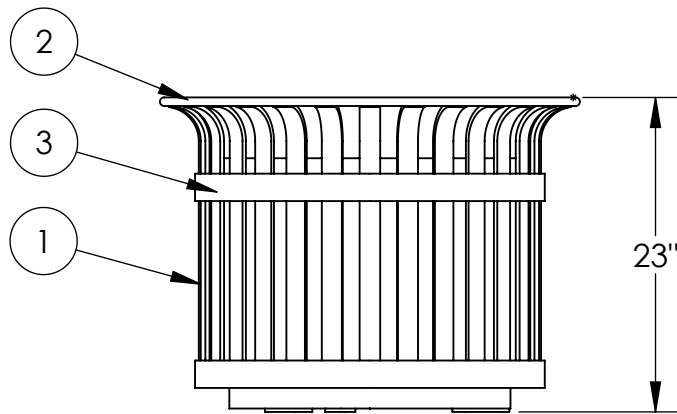

FRONT VIEW

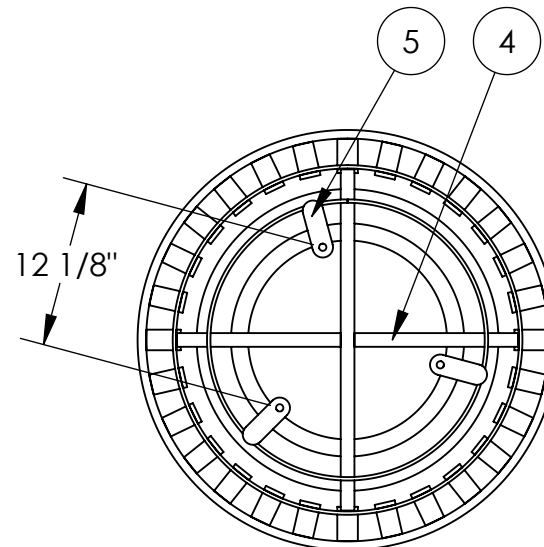

BOTTOM VIEW  
MOUNTING DETAIL

