



P.O. Box 22326
Lincoln, NE 68542

PF: 402/421-9464 | WEBSITE: www.sitescapesonline.com
FX: 402/421-9479 | E-MAIL: info@sitescapesonline.com

TITLE *CAMBRIDGE
TRASH RECEPTACLE*

PRODUCT NO.
CM2-1001

INCH TOLERANCES U.O.S.

FRACTION-- $\pm 1/16"$
ANG----- $\pm 1^\circ$

THE INFORMATION CONTAINED IN THIS DRAWING IS THE SOLE PROPERTY OF SITESCAPES, INC. ANY REPRODUCTION IN PART OR AS A WHOLE WITHOUT THE WRITTEN PERMISSION OF SITESCAPES, INC. IS PROHIBITED.

*Available in powder coat and DuraCoat finishes

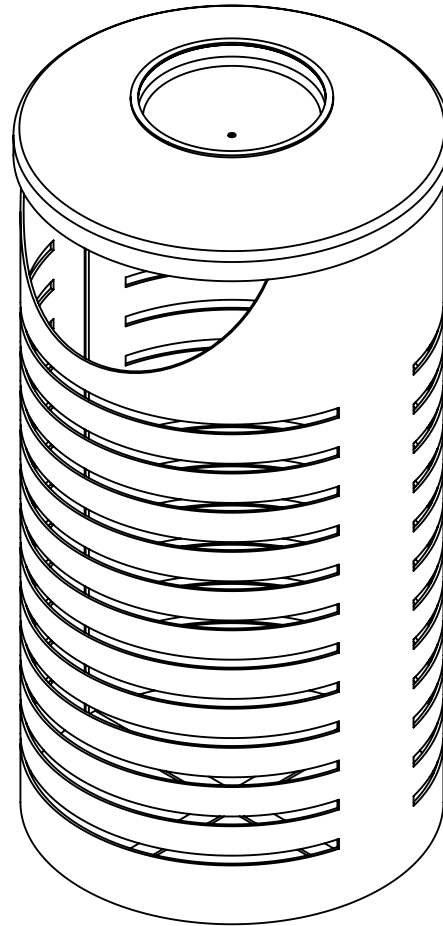



P.O. Box 22326
Lincoln, NE 68542

PF: 402/421-9464 | WEBSITE: www.sitescapesonline.com
FX: 402/421-9479 | E-MAIL: info@sitescapesonline.com

TITLE *CAMBRIDGE
TRASH RECEPTACLE*

PRODUCT NO.
CM2-1001

INCH TOLERANCES U.O.S.
FRACTION-- $\pm 1/16"$
ANG----- $\pm 1^\circ$

THE INFORMATION CONTAINED IN THIS DRAWING IS THE SOLE PROPERTY OF SITESCAPES, INC. ANY REPRODUCTION IN PART OR AS A WHOLE WITHOUT THE WRITTEN PERMISSION OF SITESCAPES, INC. IS PROHIBITED.

*Available in powder coat and DuraCoat finishes

MATERIALS LIST

- (1) Container - 7 Ga. Steel Sheet Metal
- (2) Dome - ϕ 18" x .105" Wall Steel Dome
- (3) Ash Inlay - 13 Ga. Stainless Steel Ash Inlay
- (4) Mounted with Three or Four ϕ 1/2" x 4-5" Stainless Steel Anchor Bolts (Customer Supplied)
- (5) 20 Gallon Rigid Plastic Liner with Handles Included

