



SITESCAPES

P.O. Box 22326
Lincoln, NE 68542

PF: 402/421-9464
FX: 402/421-9479

WEBSITE: www.sitescapesonline.com
E-MAIL: info@sitescapesonline.com

TITLE

*AVONDALE
RECEPTACLE*

PRODUCT NO.

AV2-3003

INCH TOLERANCES U.O.S.

FRACTION-- $\pm 1/16"$
ANG----- $\pm 1^\circ$

THE INFORMATION CONTAINED IN THIS DRAWING IS THE SOLE PROPERTY OF SITESCAPES, INC. ANY REPRODUCTION IN PART OR AS A WHOLE WITHOUT THE WRITTEN PERMISSION OF SITESCAPES, INC. IS PROHIBITED.

*Available in powder coat and DuraCoat finishes

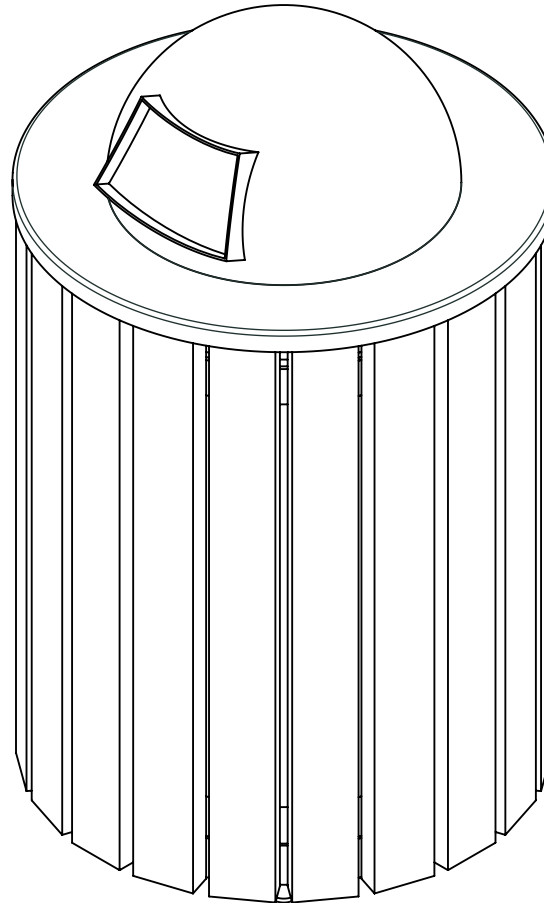



SITESCAPES

P.O. Box 22326
Lincoln, NE 68542

PF: 402/421-9464

FX: 402/421-9479

WEBSITE: www.sitescapesonline.com

E-MAIL: info@sitescapesonline.com

TITLE
**AVONDALE
RECEPTACLE**

PRODUCT NO.
AV2-3003

FRACTION-- $\pm 1/16"$
ANG----- $\pm 1^\circ$

THE INFORMATION CONTAINED IN THIS DRAWING IS THE SOLE PROPERTY OF SITESCAPES, INC. ANY REPRODUCTION IN PART OR AS A WHOLE WITHOUT THE WRITTEN PERMISSION OF SITESCAPES, INC. IS PROHIBITED.

*Available in powder coat and DuraCoat finishes

MATERIALS LIST:

- (1) Slats - 2" x 4" Nominal Ipe Wood
- (2) Support Ring - 7 Gauge Laser Cut Steel
- (3) Support Bars - 3/8" x 3/4" Steel Flat Bar
- (4) Surface Mount Plates - 1/4" x 1 1/2" Stainless Steel Plate with 9/16" Mounting Hole
- (5) Lid - $\phi 18 1/2"$ Dome Steel Lid with Hinging Door Attached to Basket with Stainless Steel Airline Cable
- (6) Mounted with Three $\phi 1/2"$ x 4-5" Stainless Steel Anchor Bolts (Customer Supplied)
- (7) Rigid Plastic 36 Gal. Liner with Handles Included

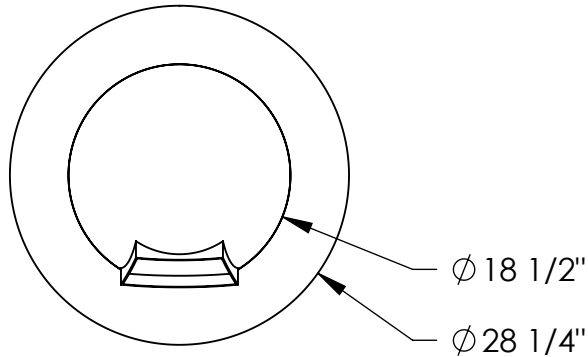

TOP VIEW

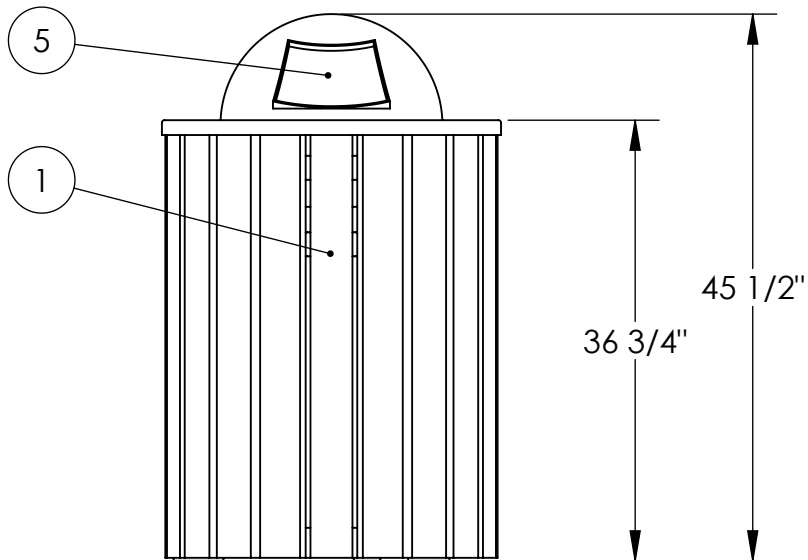

FRONT VIEW

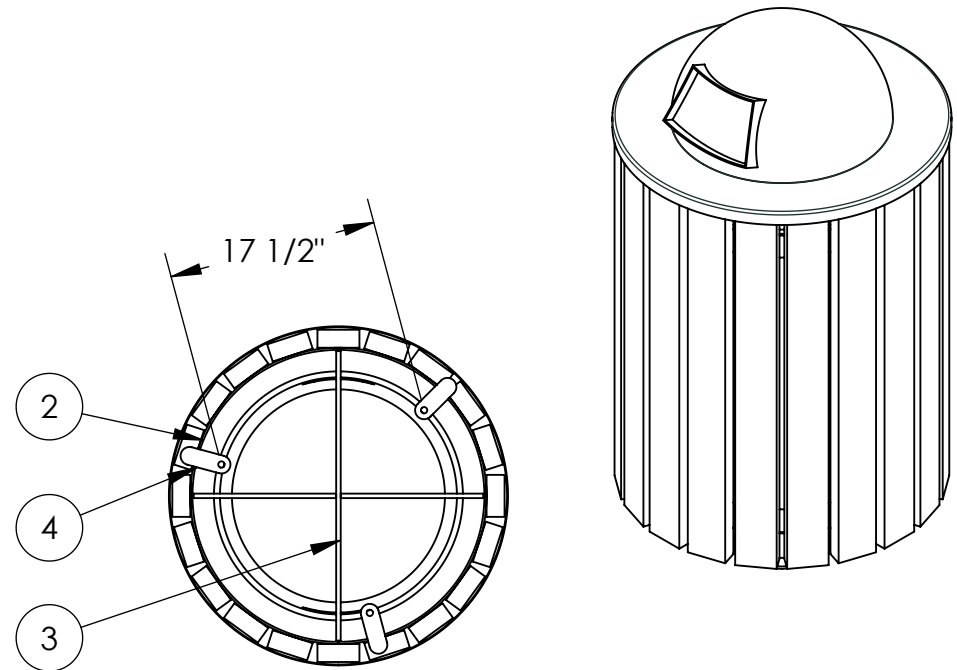

BOTTOM VIEW
MOUNTING DETAIL

