



P.O. Box 22326  
Lincoln, NE 68542

PF: 402/421-9464 | WEBSITE: [www.sitescapesonline.com](http://www.sitescapesonline.com)  
FX: 402/421-9479 | E-MAIL: [info@sitescapesonline.com](mailto:info@sitescapesonline.com)

TITLE *AVONDALE  
BACKLESS BENCH*

PRODUCT NO.  
*AV1-1130*

INCH TOLERANCES U.O.S.

FRACTION--  $\pm 1/16"$   
ANG-----  $\pm 1^\circ$

THE INFORMATION CONTAINED IN THIS DRAWING IS THE SOLE PROPERTY OF SITESCAPES, INC. ANY REPRODUCTION IN PART OR AS A WHOLE WITHOUT THE WRITTEN PERMISSION OF SITESCAPES, INC. IS PROHIBITED.

\*Available in powder coat and DuraCoat finishes

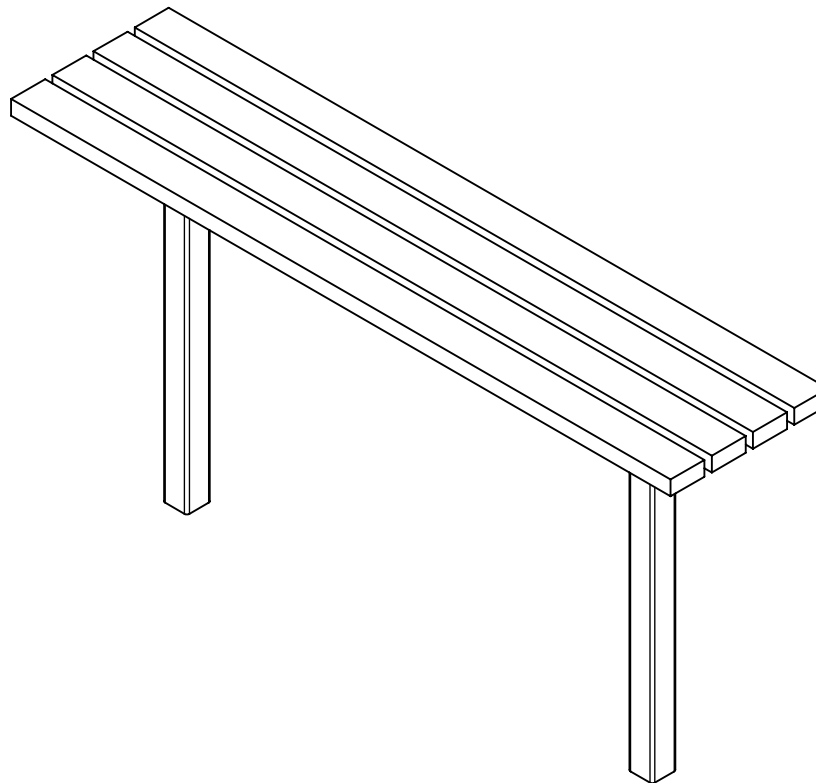



P.O. Box 22326  
Lincoln, NE 68542

PF: 402/421-9464 | WEBSITE: [www.sitescapesonline.com](http://www.sitescapesonline.com)  
FX: 402/421-9479 | E-MAIL: [info@sitescapesonline.com](mailto:info@sitescapesonline.com)

INCH TOLERANCES U.O.S.

FRACTION--  $\pm 1/16"$   
ANG-----  $\pm 1^\circ$

THE INFORMATION CONTAINED IN THIS DRAWING IS THE SOLE PROPERTY OF SITESCAPES, INC. ANY REPRODUCTION IN PART OR AS A WHOLE WITHOUT THE WRITTEN PERMISSION OF SITESCAPES, INC. IS PROHIBITED.

TITLE *AVONDALE  
BACKLESS BENCH*

PRODUCT NO.  
*AV1-1130*

\*Available in powder coat and DuraCoat finishes

MATERIALS LIST:

- (1) Seat Slats - 2" x 4" Ipe Wood Slats
- (2) Support Plates - 3/8" Steel Plate
- (3) Support Tubing - 2 1/2" Square Steel Tubing

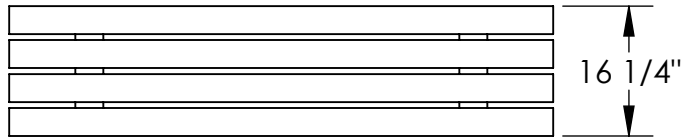

TOP VIEW

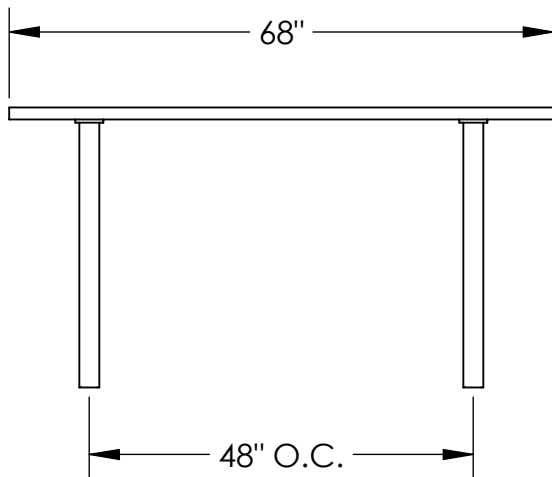
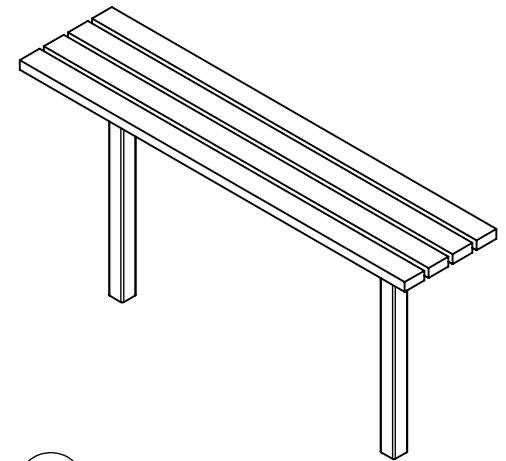

FRONT VIEW

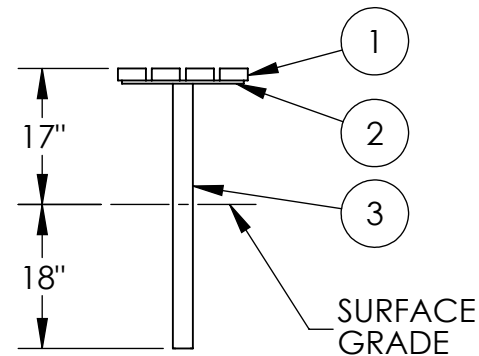

RIGHT SIDE VIEW